

ADJUSTABLE METAL BACK - UL LISTED

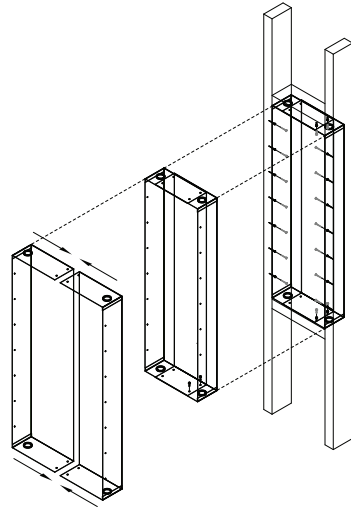

Included steel brackets attach to sides for use with metal framing.



Wood stud configuration
Add framing above and below.

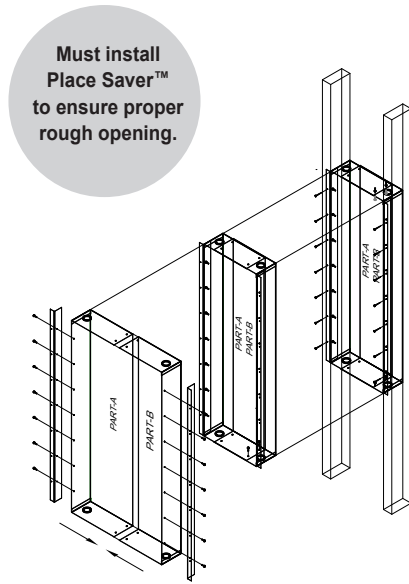

Metal stud / hat channel configuration

Must install Place Saver™ to ensure proper rough opening.



Recommended Applications:

The versatile, UL listed MBA back boxes are built to adapt to whatever you have to work with on the job site. MBA back boxes are recommended for installations:

1. Where the space behind the speaker is open;
2. Where a metal closure is required and the mounting distance between the framing members is less than 16" (406 mm) on center;
3. When using metal studs or hat channel/suspended hard lid ceilings.

Construction:

Constructed of 1.1 mm thick metal, the MBA series back boxes are shipped unassembled, ready for your custom configuration needs and UL listed. Convenient 1/2" (13 mm) and 3/4" (19 mm) knockouts for conduit are provided.

Included Accessories:

Screw package and foam pads, Dynamat adhesive box insulation, and 3/4" (19 mm) x 1 1/2" (38 mm) metal mounting angles.

Shipping Weight:

MBA-22:	10 lbs.	(4.5 kg)	each
MBA-30:	13 lbs.	(5.9 kg)	each

Dimensions:

Model:	MBA-30	MBA-22
Use With:	LR3G, B30G	LR4G-LFG, LR4G-HM, LR8G, SLR8G, LR6G B22G
Width:	9 3/4" to 14 1/2" (247-368 mm)	9 3/4" to 14 1/2" (247-368 mm)
Height:	28 1/2" (722 mm)	20 1/2" (519 mm)
Depth:	3 1/2" (89 mm)	3 1/2" (89 mm)

Architectural and Engineering Specifications:

The adjustable metal back box shall be constructed of 1.1 mm steel. UL listed and plenum rated, the MBA back boxes are code compliant. The MBA series is for use with wood, metal, or hat channel framing. The back box shall adjust from 9 3/4" (247 mm) wide to 14 1/2" (368 mm) wide and be only 3 1/2" (89 mm) in depth. The MBA series shall include two metal angles for secure mounting into either metal or wood studs or hat channel. The back boxes shall also include all mounting screws and one sheet of Dynamat to cover the center seam. The

boxes will have both 1/2" (13 mm) and 3/4" (19 mm) knockouts for wire passage.

Installation Notes:

1. The back box interior should be insulated before speakers are installed.
2. To avoid direct contact of woofer magnet to back of enclosure, a thin piece of foam (included in the accessory package) should be placed between the woofer magnet(s) and the box.
3. Increased acoustical isolation is possible by using a visco-elastic acoustic barrier, such as Dyniltm by Dynamic Control (dynamat.com). This material is ultra pliable and only 0.09" (2.2 mm) thick, allowing it to fit behind the speaker panels.